

BGSFPV-001-ONE

(Ultra-Compact Anti-Jamming Terminal Designed for FPV)

specification

1. Product overview

This product integrates GNSS full-frequency reception with integrated navigation algorithms to achieve high-precision positioning and anti-jamming capabilities. It effectively addresses challenging environments including satellite signal interference, occlusion, and multipath effects, delivering continuous, real-time, and reliable high-precision positioning results with robust anti-jamming performance.



2. product formation

Product composition and accessories are as follows.

Table 1 System composition and supporting table

order number	name	quantity	remarks
1	Anti-interference positioning module	1 unit	
2	interface cable	1 root	

3. Physical configuration

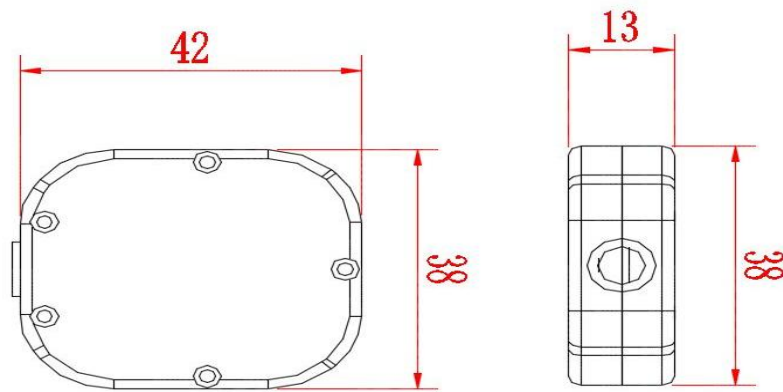

Figure 1 Product structure diagram

4. technical parameter

Specifications	parameter
support system	BDS, GPS
Single point positioning accuracy	$\leq 2\text{m}$ (1σ , PDP ≤ 4) (under no interference) $\leq 5\text{m}$ (1σ , PDP ≤ 4) (under interference)
First positioning time	Cold start time: $\leq 40\text{s}$; Hot start time: $\leq 5\text{s}$; Unlock recapture time: $\leq 2\text{s}$.
motion fitness	Speed: $\leq 500\text{m/s}$; Acceleration: $\leq 4\text{g}$.
Timing accuracy	$\leq 20\text{ ns}$ (RMS)
capacity of resisting disturbance	65dBc

Specifications	parameter
power dissipation	$\leq 60\text{mA}@5\text{V}$
joggle	1 x UART TTL
size	$(42\pm 1)\times(38\pm 1)\times(13\pm 1)\text{mm}$
weight	$32\pm 1\text{g}$

5. Interface definitions

5.1 External interface connector and cable requirements

The connection diagram of external interface connector and cable is as follows.

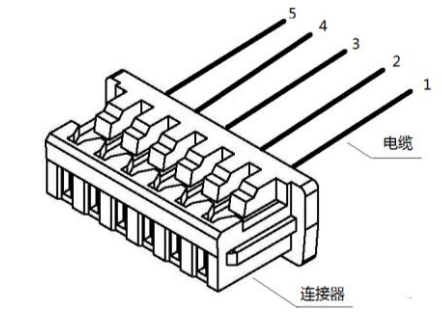

Figure 2 shows the connector and cable connection

5.2 Data power interface, 5-core rectangular plug A1251H-5P, defined as follows:

contact	name	I/O	Signal characteristics
1	GND	0	the earth
2	5V	1	source
3	TX	0	Module output, TTL level
4	SGND	0	Signal ground
5	RX	1	Module input, TTL level

6. Data protocol

6.1 Standard NMEA0183 protocol, baud rate 115200;

6.2 The default output location is XXGGA, XXRMC, XXVTG and XXGST information;

6.3 Refresh rate: 10Hz.

7. Environmental adaptability requirements

7.1 Working temperature: $-40^{\circ}\text{C} \sim +65^{\circ}\text{C}$;

7.2 Storage temperature: $-45^{\circ}\text{C} \sim +85^{\circ}\text{C}$;

7.3 Relative humidity: $\leq 95\%$ (non-condensation).

7.4 Vibration: meet the working environment requirements of UAV.

8. Installation Guide

8.1 The installation position shall ensure that the antenna has a 180° sky viewing range

8.2 Avoid proximity to metal objects or sources of electromagnetic interference

8.3 The antenna installation surface should be kept level

9. matters need attention

9.1 The anti-interference positioning module is tested in an outdoor environment without obstruction and electromagnetic interference that affects the operation of the module, or in an indoor environment with a signal repeater.

9.2 This equipment contains sensitive electronic components. Prohibited:

9.2.1 Disassembling the shell without authorization

9.2.2 Supplying power beyond the rated voltage range