

BGS-4CH-UCV-04
4-Element Anti-jamming Terminal
(Ultra-compact version - Single frequency:
B1I/L1C)
product specification



Preparation / Date: _____

Review / Date: _____

Approval / Date: _____

catalogue

■ product presentation.....	3
■ product function.....	3
■ behaviour of electricity	3
■ Interface definition.....	4
■ structural requirement.....	5
■ Product identification.....	6
■ environmental suitability.....	6
■ Typical application occasions	6
■ Connection relationship description.....	6
■ Installation and use.....	7
■ Docking with the flight control protocol.....	8
■ Disclaimer.....	8

■ product presentation

BGS-4CH-UCV-04 ultra-miniaturization anti-interference all-in-one machine is a satellite navigation anti-interference all-in-one machine for the needs of small and medium-sized UAV and other industries, which supports the anti-broadband interference ability and positioning function of BDS B1 and GPS L1 frequency point signals. Internal integrated antenna array, anti-jamming components and satellite navigation receiver, with miniaturization, lightweight, and low cost characteristics.

■ product function

1. RNSS signal reception

1) With the function of receiving RNSS signals from navigation satellites such as Beidou-3 and GPS

2) Civil code: BDS B1 and GPS L1

2. Anti-interference function

With the anti-interference function of B1 and L1 frequency points, it can suppress narrowband interference, broadband interference, pulse interference, sweep interference, Gaussian interference and other suppression interference

3. Software upgrade

With the software upgrade function, you can upgrade the anti-interference module and the receiver module through the serial port

4. System self-inspection

It has self-check and status inspection functions

5. Anti-burning function

The continuous W power is not less than 10W

■ behaviour of electricity

1. Frequency of work

B1I: 1561.098MHz; L1: 1575.42MHz

2. Anti-interference performance

Unidirectional interference $\geq 95\text{dBc}$

Two-direction interference $\geq 85\text{dbc}$

Three-direction interference $\geq 80\text{dBc}$

3. Positioning accuracy

Under no interference: Horizontal $\leq 1.5\text{ m}$, Vertical $\leq 1.5\text{ m}$

Under interference: Horizontal $\leq 10\text{ m}$, Vertical $\leq 10\text{ m}$

4. Speed measurement accuracy

0.2 m / second (95%)

5. Time-giving accuracy

$\leq 100\text{ns}$ (95%)

6. Operating voltage

The input voltage is 5 to 17 V

7. Power consumption

$\leq 6\text{W}$

■ Interface definition

The interface definitions are shown in the following table:

No.	code name	Connector model	functional description
1	TX	SM A -KF D	GNSS RF output port, reserved
2	data	J30J-9ZKP	5~17V power supply input and serial port

1. Power supply / data interface

The J30J-9 ZK core connector is selected, and the pin is defined as follows:

Pin No.	name	direction	electrical level	remarks
1	Power positive pole	import	5~17V	It is recommended that 12V
2	Power positive pole	import	5~17V	It is recommended that 12V

3	Power anode	import		
4	Power anode	import		
5	RXD0	import	TTL	Upgrade with serial port
6	TXD0	output	TTL	
7	RXD1	import	TTL	Anti-interference serial port
8	TXD1	output	TTL	
9	GND	import	TTL	

2. RF interface

1) Anti-interference signal output interface (reserved), using SMA connector, and for the first-line form

2) The signal level of the output B1 \ L1 is -70~ -60 dBm

■ structural requirement

1、 Overall dimensions: 65x65x21mm

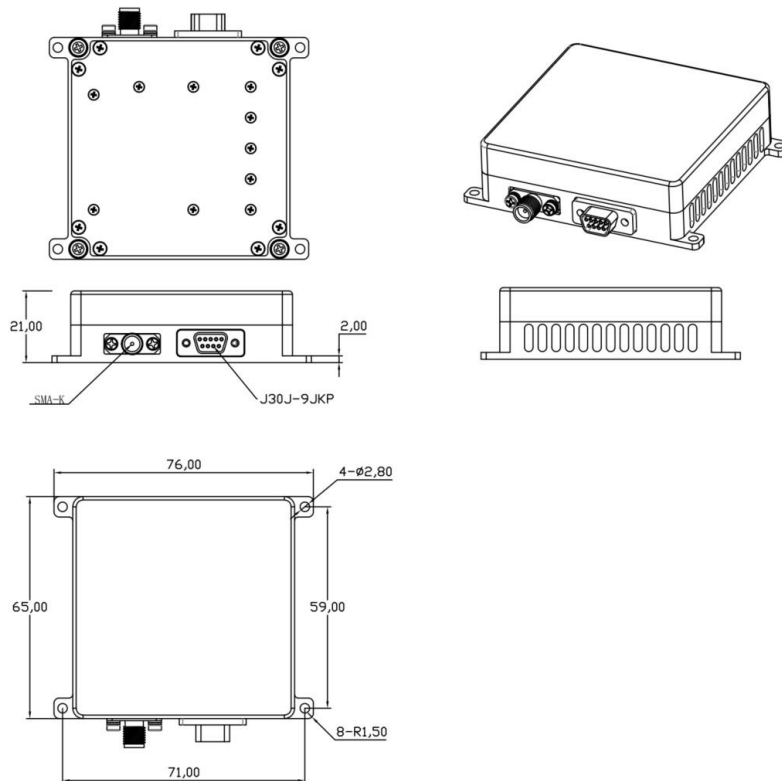

2、 Weight: ≤130g

3、 Color: gray

■ Product identification

product name:
product model:
serial number:
date of manufacture:
manufacturer:

■ environmental suitability

- 1. Operating temperature:** -40°C ~ + 55°C
- 2. Storage temperature:** -55°C ~ + 70°C
- 3. Relative humidity: temperature:** 40°C; humidity: 96%
- 4. Rain:** meet the requirements of GJB150A rain test

■ Typical application occasions

1. Power, communications, finance and other fields of time security
2. Uaerial vehicles, unmanned vehicles, unmanned ships and other navigation safety
3. Convoy defense and navigation security
4. High-end logistics and navigation security

■ Connection relationship description

1. The electrical signal connection of the product and the platform carrier is connected by low-frequency data mode.
2. This product has a built-in locator, which can replace the conventional positioning terminal and antenna. The following schematic diagram:

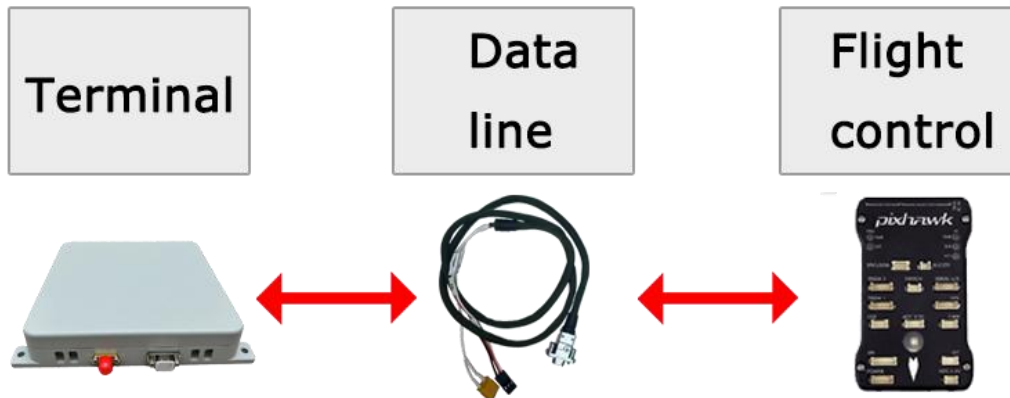

3. In the RF signal access mode, this product replaces the conventional active antenna. The following schematic diagram.

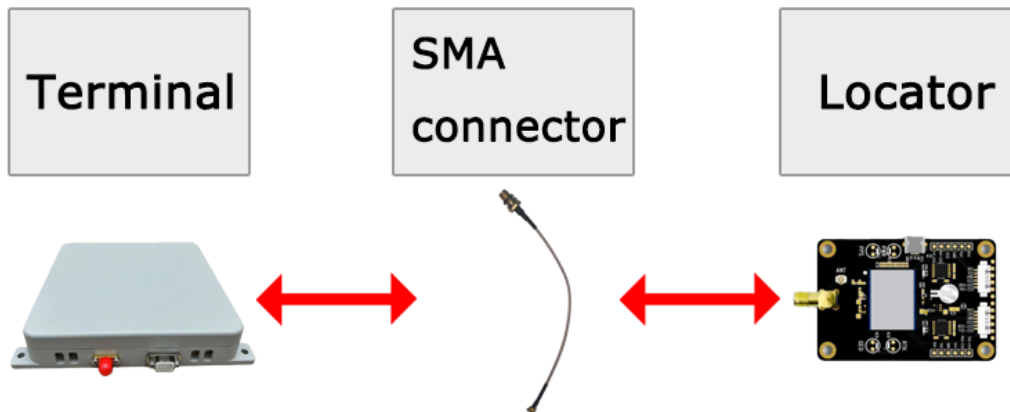

4. When using usb to TTL tool to connect to the computer, do not plug usb to damage the serial port.

■ Installation and use

1. fixed

Install fixation with M 2 screws.

2. supply electricity

Use XT 30 power supply, power supply voltage 5-17V, maximum not exceeding 17V, recommended to use 12V.

3. Locate the data connection

1) Connect the DuPont line TTL serial port of this product to the flight control GNSS serial port.

Connect the flight control to the GNSS serial port using the matching data line provided by this product. Connect one end of the data line label TX to the flight control RX interface, one end

of the label RX to the flight control TX interface, and one end of the label GND to the flight control GND interface.

2) Use the SMA cable to connect the RF port of the product to the antenna port of the UAV locator.

■ Docking with the flight control protocol

This product shall output nmea, protocol or ublox protocol, and the flight control shall be set to receive either of these two protocols. Please ask the customer to complete the agreement docking work with our technical personnel before placing an order.

■ Disclaimer

This product is designed to improve the security of satellite navigation. Please comply with the relevant laws and regulations during the use. Any illegal activities with the product.