

BGS-4CH-SDV-BD-01
4-Element Anti-jamming Terminal
(Standard Version-Dual
-frequency:B1C/L1C and B3I)
product specification



Proposed/Date: _____

Review/Date: _____

Ratification/Date: _____

catalogue

■ Product presentation.....	1
■ Product function.....	1
■ Behaviour of electricity.....	2
■ Interface definition	3
■ Shape structure.....	4
■ Product identification.....	5
■ Environmental suitability.....	5
■ Typical application scenarios	6
■ Connection relationship description.....	6
■ Installation and use.....	7
■ Connect with flight control protocol	7
■ Disclaimer	7

■ Product presentation

This product model is BGS-4CH-SDV-BD-01.it is a miniaturized satellite navigation anti-jamming integrated device designed for civilian drones and industry users, supporting the reception of dual-band signals from BeiDou-2, BeiDou-3 RNSS B1/B3, and GPS L1, supporting dual-system anti-band jamming capability, with a maximum jamming resistance of 3. It integrates an antenna array, anti-jamming components, and a satellite navigation receiver, serving reliable navigation fields such as drones and unmanned vehicles, protecting user terminals from various unintentional and malicious attacks, significantly enhancing PNT information security.

■ Product function

1. RNSS signal reception

1) It has the function of receiving RNSS signals from Beidou-2, Beidou-3 and GPS navigation satellites

2) Civil code: B1C, B3I, L1C/A

2. Anti-interference function

It has anti-jamming function with B1C, B3I and L1C/A dual frequency points, which can suppress narrowband interference, broadband interference, pulse interference, sweep interference and Gaussian interference

3. Built-in full frequency point navigation and positioning module, output information according to NMEA0183 protocol.

4. Serial port output or RF port output can be used.

5 Software upgrade

It has the function of software upgrade, which can be upgraded through serial port interference fighting module and receiver module

6. System self-inspection

It has self-inspection and status inspection functions

7. Fire resistance function

The anti-continuous wave power shall not be less than 10W

8. Safety

Overvoltage protection, reverse connection protection, etc

■ Behaviour of electricity

1. Working frequency

BDS-B3:1268.52MHz±10.23MHz

BDS-B1:1575.42MHz±16.368MHz

GPS-L1:1575.42MHz±16.368MHz

2. Anti-interference performance

Unidirectional interference: ≥95dB, Three-direction interference: ≥85dB

3. Positioning accuracy

Horizontal ≤ 1.5 meters

4. Speed measurement accuracy

≤ 0.2 m/s

5. Timing accuracy

≤ 100 ns

6. Working voltage

Input voltage 5~17V

7. Power consumption

≤ 17 W

■ Interface definition

1. Power/data interface

The J30J-9ZK core connector is selected, and the pin definition is as follows:

No.	name	direction	electrical level	remarks
1	Positive pole	import	5~17V	Recommended 12V
2	Positive pole	import	5~17V	Recommended 12V
3	Negative pole	import		
4	Negative pole	import		
5	RXD0	import	TTL	Upgrade to serial port
6	TXD0	output	TTL	
7	RXD1	import	TTL	Anti-interference serial port
8	TXD1	output	TTL	

9	GND	import	TTL	
---	-----	--------	-----	--

2. RF interface

- 1) Anti-interference signal output interface, using SMA connector and in the form of one line
- 2) The signal level of output B3/B1 is -70~-60dBm

■ Shape structure

1. Appearance size

150mm×130mm×26.5mm

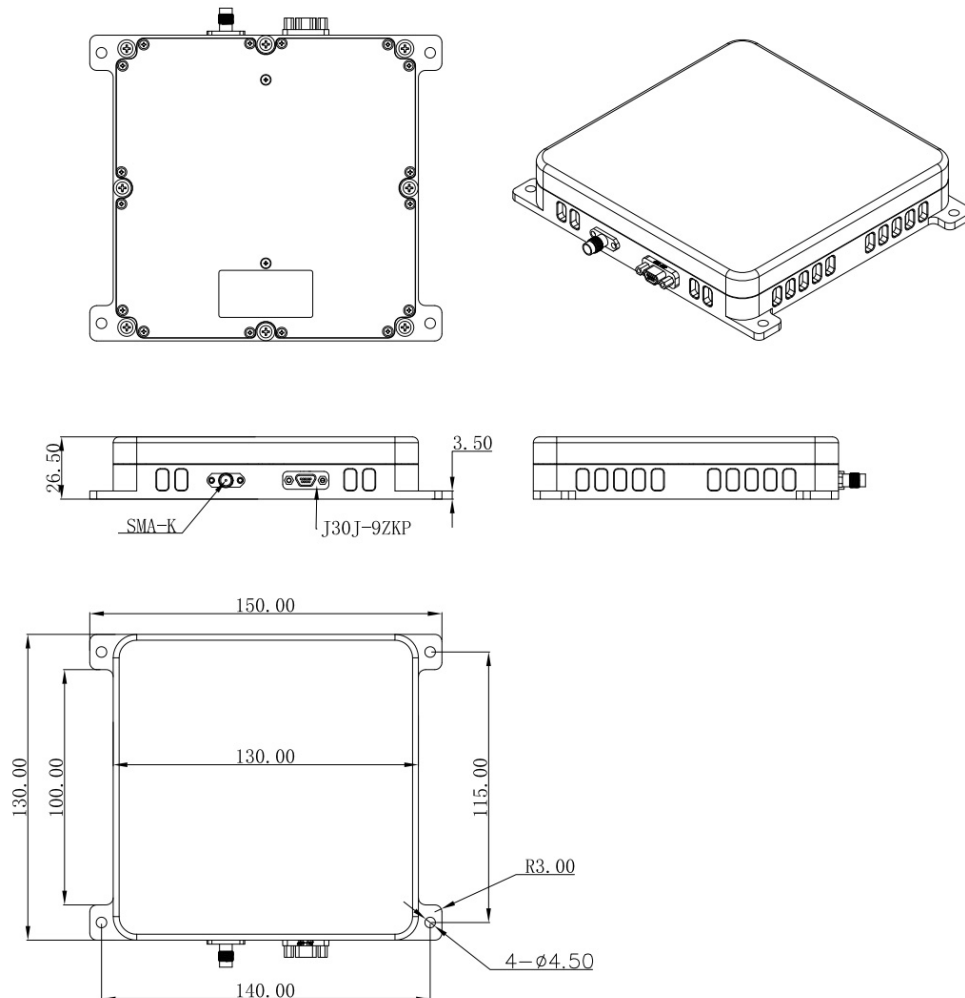

2. Weight

≤500g

3. Color

French grey

■ Product identification

product name:
product model:
serial number:
date of manufacture:
manufacturer:

■ Environmental suitability

1. Operating temperature:

-40°C~+55°C

2. Storage temperature:

-55°C~+70°C

3. Relative humidity:

Temperature 40°C; humidity: 96%

4. Rain:

Satisfy the GJB150A rain test requirements

■ Typical application scenarios

1. Time synchronization security in power, communications and finance
2. Navigation safety for drones, unmanned cars and unmanned ships
3. Vehicle defense navigation safety
4. High-end logistics navigation safety

■ Connection relationship description

1. The telecommunication signal connection between the product and the platform carrier is connected by low frequency data method.
2. The product has a built-in locator that can replace the conventional positioning terminal and antenna. As shown in the following figure:

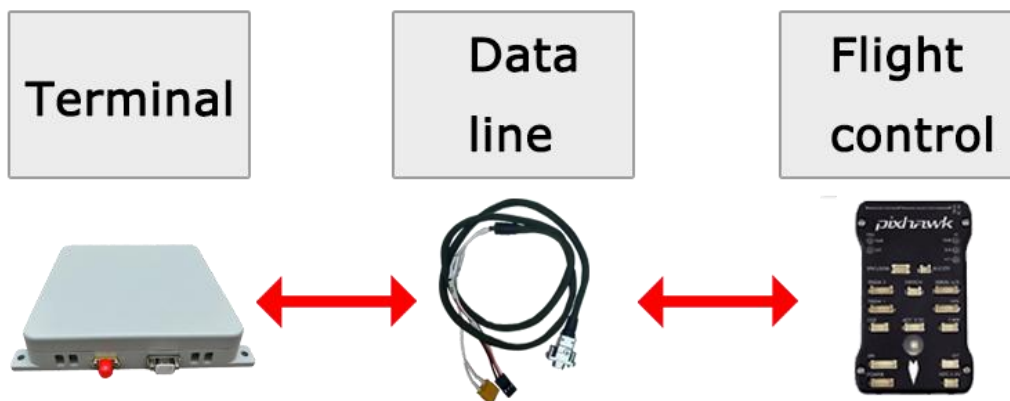

3. In RF signal access mode, this product replaces the conventional active antenna. When connecting using the RF interface of this product, please ensure that the interface of the connected party does not provide an over 5V power supply to this product to avoid possible power conflicts or damage. As shown in the following diagram.

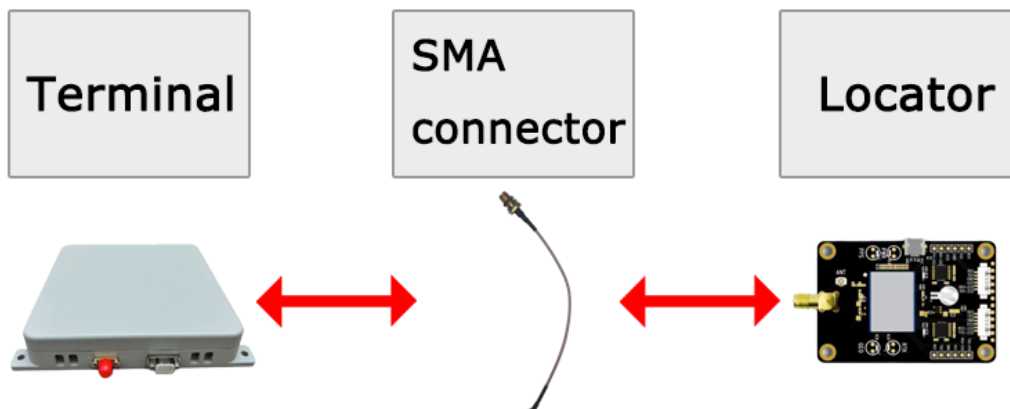

4. When using the USB to TTL tool to connect with the computer, do not plug or unplug the USB with power to avoid damaging the serial port.

■ Installation and use

1. fixed

Use M3 screws for installation and fixation.

2. supply electricity

Use XT30 power supply, power voltage 5-17V, maximum not more than 17V, it is recommended to use 12V.

3. Position data connection

1) Connect the DuPont line TTL serial port of this product to the GNSS serial port of the flight control.

Use the accompanying data cable provided with this product to connect to the GNSS serial port of the flight controller. Connect the end labeled TX to the RX interface of the flight controller, the end labeled RX to the TX interface of the flight controller, and the end labeled GND to the GND interface of the flight controller.

2) Use the SMA cable to connect the products RF port to the drone locators antenna port.

Note: Either serial port or RF port is sufficient.

■ Connect with flight control protocol

This product outputs nmea 0183 protocol.

■ Disclaimer

This product is designed to enhance the safety of satellite navigation. Please comply with relevant laws and regulations when using this product. Any illegal activities carried out using this product are not related to this product.