

BGS-16CH-AJAS-02

16-Element Dual Anti-jamming Terminal

(Anti-jamming + Enhanced Anti-Spoofing)

Product Specification



Drafted/Date: _____

Review/Date: _____

Approved/Date: _____

Catalogue

■ Product Presentation	1
■ Product Functions	1
■ Electrical Performance	2
■ Interface Definition	3
■ Mechanical Structure	4
■ Product Label	5
■ Environmental Adaptability	5
■ Typical Application Scenarios.....	5
■ Connection Relationship Description.....	6
■ Installation and Use.....	7
■ Interface with Flight Control Protocol	7
■ Disclaimer	7

■ Product Presentation

Model: BGS-16CH-AJAS-02 is a satellite navigation anti-jamming terminal designed for industrial user needs. It supports BDS-B1i and GPS-L1 frequencies, featuring anti-suppression jamming capability (maximum 15 jammers) and anti-spoofing capability. Internally integrated with an antenna array, anti-jamming components, and a satellite navigation receiver, it serves reliable navigation fields such as UAVs (Unmanned Aerial Vehicles) and unmanned vehicles. It protects user terminals from various unintentional interferences and malicious attacks, significantly improving the security of PNT information.

■ Product Functions

1. RNSS Signal Reception

- 1) Capable of receiving RNSS signals from Beidou and GPS navigation satellites.
- 2) Civil codes: BDS B1i and GPS L1.

2. Anti-Jamming Function

Equipped with anti-jamming function for BDS-B1 and GPS-L1 frequencies, capable of suppressing suppressive jamming such as narrowband jamming, wideband jamming, pulse jamming, frequency sweep jamming, and Gaussian jamming.

3. Anti-Spoofing Function

Equipped with anti-spoofing function for L1 and B1 frequencies, capable of suppressing asynchronous spoofing, synchronous spoofing, and repeater spoofing. It outputs pure signals to the backend receiver.

4. Software Upgrade

Supports software upgrade function; the anti-jamming module and receiver module can be upgraded via serial port.

5. System Self-Test

Has self-test and status inspection functions.

6. Anti-Burnout Function

Withstands continuous wave power of not less than 10W.

7. Safety

Equipped with overvoltage protection, reverse connection protection, etc.

■ Electrical Performance

1. Operating Frequency

BDS-B1: 1561.098 MHz \pm 2.046MHz

GPS-L1: 1575.42MHz \pm 2.046MHz

2. Anti-jamming Performance (Zero Adjustment)

ISR:single \geq 110dB; seven \geq 95dB; fifteen \geq 90dB

3. Anti-Spoofing Performance

Residual spoofing signal CN0 (Carrier-to-Noise Ratio) \leq 20 dB.

4. Positioning Accuracy

No jamming: Horizontal \leq 1.5 m (95%), Vertical \leq 1.5 m (95%)

With jamming: Horizontal \leq 10 m (95%), Vertical \leq 10 m (95%)

5. Speed Measurement Accuracy

\leq 0.2 m/s (95%)

6. Timing Accuracy

≤100ns (95%)

7. Operating Voltage

Input voltage 12~34V

8. Power Consumption

≤40W

■ Interface Definition

1. Power/Data Interface

Adopts J30J-15ZK connector. Pin definitions are as follows:

Pin No.	Pin Name	Direction	Level	Remarks
1~5	Positive Pole	Power Input	12~34V	Recommended 28V
6~10	Negative Pole	Power Input		
11	TXD0	Output	TTL	Anti-jamming Serial Port
12	RXD0	Input	TTL	
13	RXD1	Input	TTL	Receiver Serial Port
14	TXD1	Output	TTL	
15	GND	--	--	

2. RF Interface

- 1) Anti-jamming signal output interface adopts SMA connector with one-wire communication mode.
- 2) Output signal level: -70~-60 dBm.

■ Mechanical Structure

1. Overall Dimensions

$\Phi 370\text{mm} \times 28.7\text{mm}$

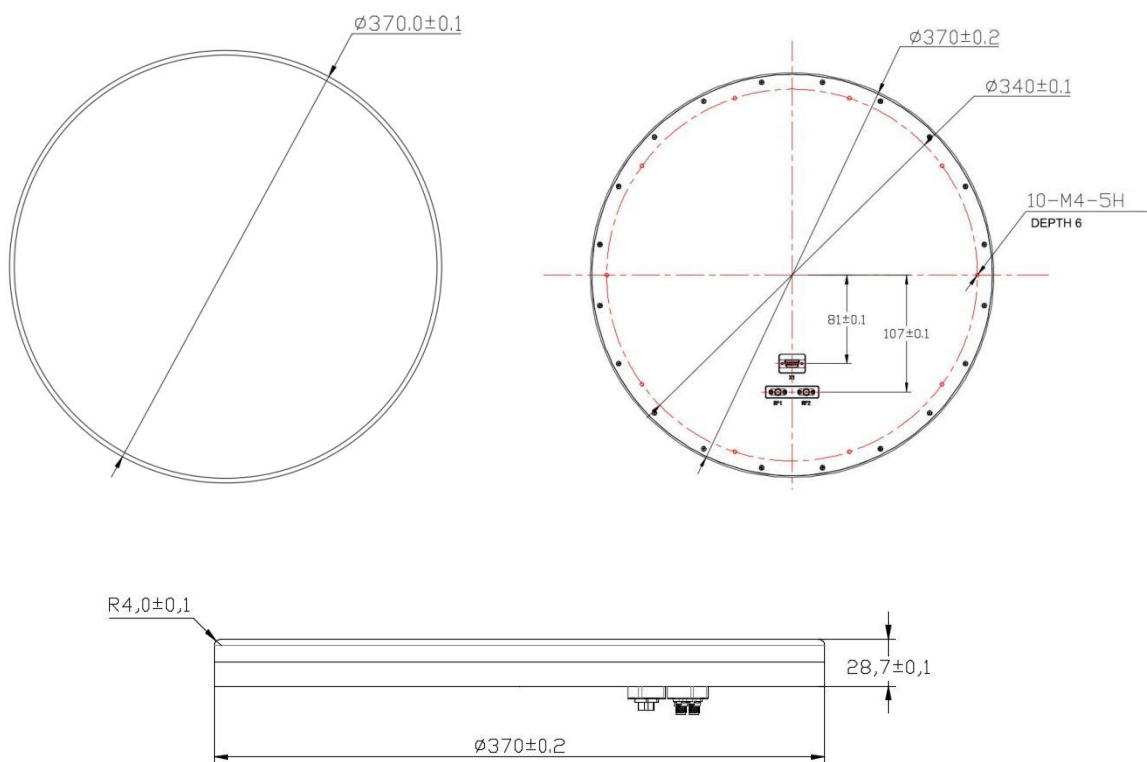

2. Weight

$\leq 2600\text{g}$

3. Color

Light Grey

■ Product Label

Product Name :
Product Model :
Serial Number :
Production Date :
Manufacturer :

■ Environmental Adaptability

1. Operating Temperature:

-40°C ~ +55°C

2. Storage Temperature:

-55°C ~ +70°C

3. Relative Humidity:

Temperature: 40°C; Humidity: 96%

4. Rain Resistance:

Meet the rain test requirements of GJB150A

■ Typical Application Scenarios

1. Timing security in power, communication, financial and other industries.
2. Navigation security for UAVs, unmanned vehicles, unmanned ships, etc.

3. Fleet defense navigation security.
4. High-end logistics navigation security.

■ Connection Relationship Description

1. The electrical signal connection between the product and the platform carrier is realized through low-frequency data mode.
2. This product has a built-in locator, which can replace conventional positioning terminals and antennas. Schematic diagram is as follows:

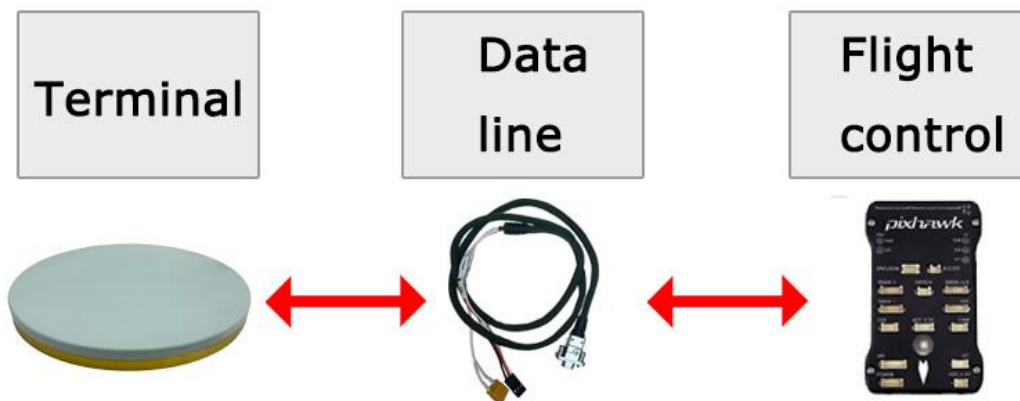

3. In RF signal access mode, this product replaces the conventional active antenna. When connecting via the product's RF interface, ensure that the access party's interface does not provide power exceeding 5V to the product to avoid potential power conflicts or damage. Schematic diagram is as follows:

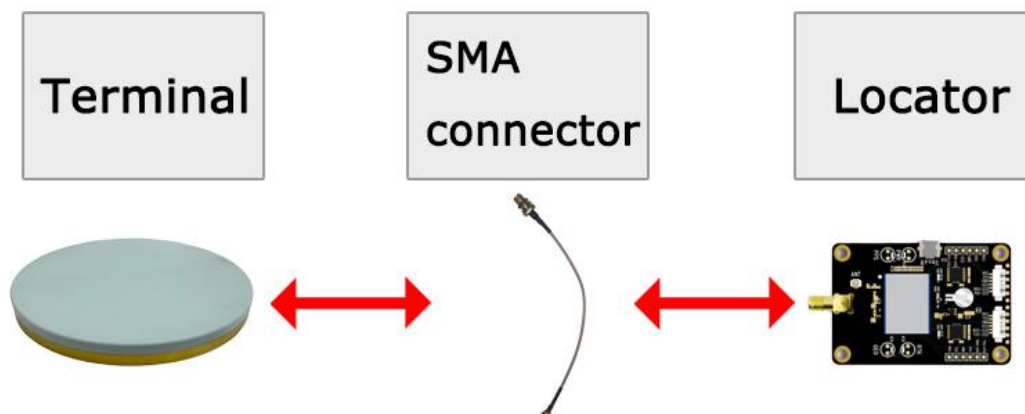

4. When connecting to a computer using a USB-to-TTL tool, do not hot-swap the USB to prevent serial port damage.

■ Installation and Use

1. Fixed

Install and fix by yourself.

2. Power Supply

Use XT30 male connector. Power supply voltage: 12-34 V (maximum not exceeding 34 V), recommended 28 V.

3. Positioning Data Connection

1) Connect the DuPont wire TTL serial port of this product to the GNSS serial port of the flight control.

Use the supporting data cable provided with the product to connect to the GNSS serial port of the flight control. Connect the end of the data cable labeled "TX" to the RX interface of the flight control, the end labeled "RX" to the TX interface of the flight control, and the end labeled "GND" to the GND interface of the flight control.

2) Use an SMA connection cable to connect the RF port of the product to the antenna port of the UAV locator.

Note: Either the serial port or the RF port can be selected.

■ Interface with Flight Control Protocol

This product uses the ublox M10 receiver by default, and can output NMEA 0183 ASCII protocol or ublox protocol.

■ Disclaimer

This product aims to enhance the security of satellite navigation. Please comply with relevant

laws and regulations during use. The manufacturer is not responsible for any illegal activities conducted using this product.